

ACIL STOK—KOMPANZASYON / EMERGENCY STORAGE – BUFFER

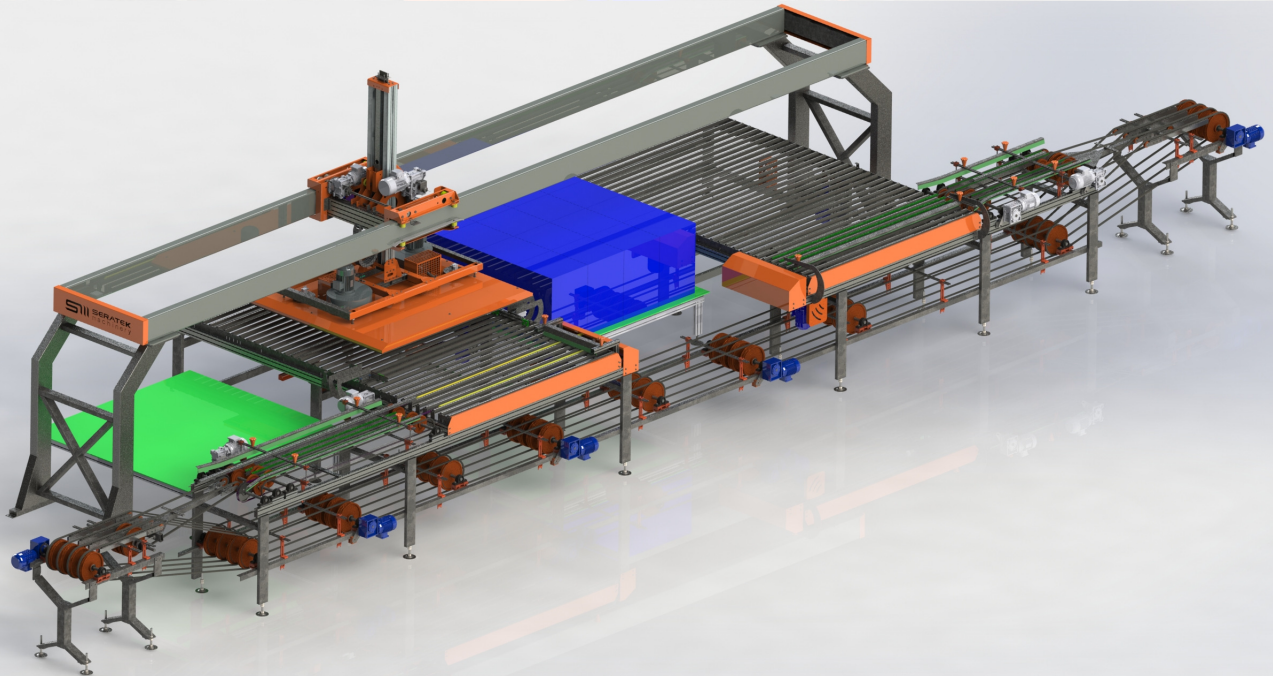

TEKNİK ÖZELLİKLER / TECHNICAL FEATURES

Model / Model	VBF
Boyutlar / Dimensions	3500mm– 15000 mm
Karo Boyutları / Tile Dimensions	20x20 to 120x120 cm
Kapasite / Capacity	3 cycles/min
Kurulu Güç / Installed Power	15 Kw
Ağırlık / Weight	3500 kg

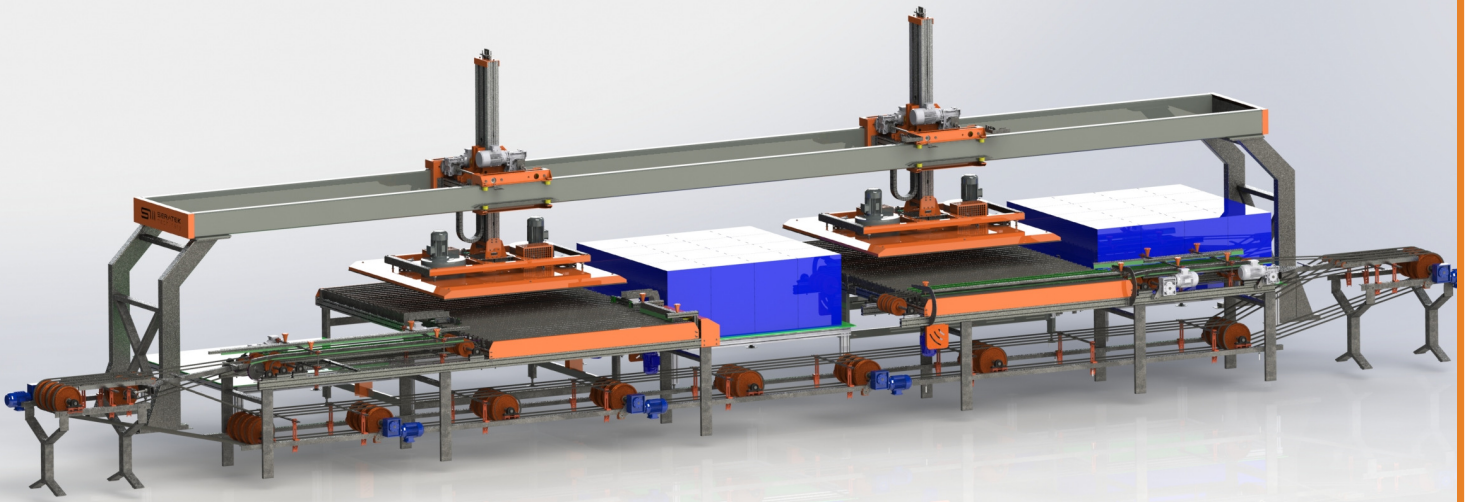
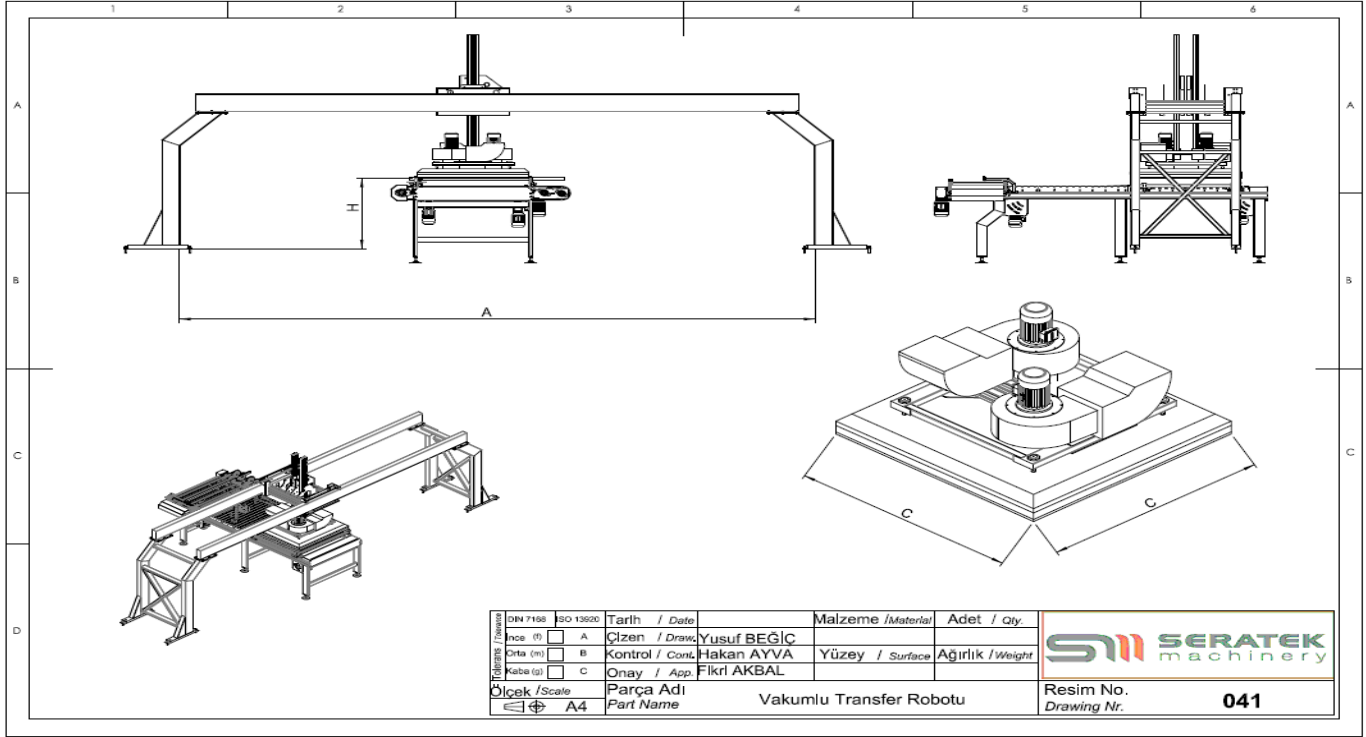

UYGULAMA ALANLARI / APPLICATION FIELDS

Fırın çıkışı, kenar taşlama ve paketlenme makinası gibi birbirine bağlı sistemlerde, duruş anında karoları stoğa almak ve duruş bittiğinde tekrar beslemek veya sürekli stoğa alıp, geri beslemek amaçlı kullanılan makinalardır.

Machines used for when kiln exit, squaring line and quality sorting line is connected together, to take tiles on the storage platforms when there is a stoppage and feed back when the system begins to work or to take the tiles on storage platforms continuously and feed back continuously.

AVANTAJLARI / ADVANTAGES

Düzgün olmayan yüzeylerde kullanabilme imkanı.

Possibility to use on structured surfaces.

Daha az çalışan parça, bakım kolaylığı.

Less working piece, easier maintenance.

Hızlı ebat değişimi.

Fast size change.

Yüzeyle sünger ile temas ettiğinden yüzey çizilmesi ve vantuz izi probleminin olmaması

By touching the surface with a sponge, no surface scratches and no sucker marks.

Hızlı ve güvenli çalışma.

Fast and safe operation.